

4 x Dia.11 mm

ITEM	QTY	DESCRIPTION	PART No	SUPPLIER
A	1	Aluminium ENCLOSURE	G23 Aluminium	Tech-Ex Systems / Petrel

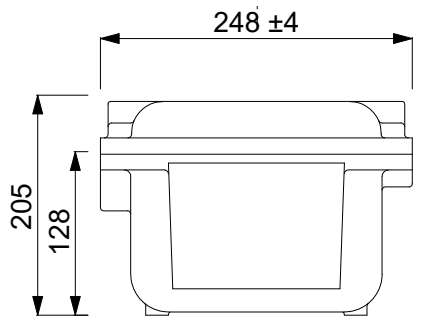
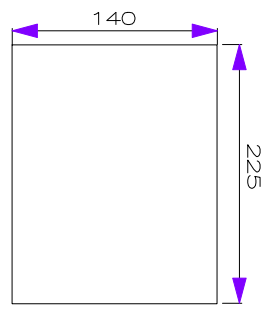
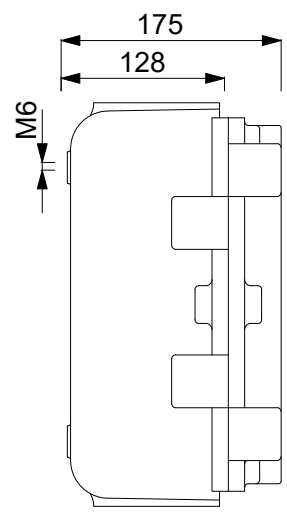
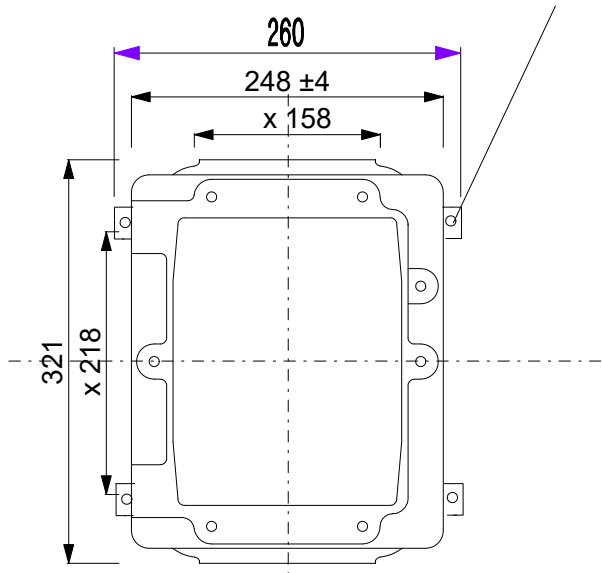

ENCLOSURE TYPE G23

1. All dimensions in millimeters
2. 2 IIGD
3. Exd IIB T6 (EN/IEC 60079.0 60079.1)
4. Certificate ITS09ATEX 16433X Issue 05
5. Protection index : IP65 / IP66 according to EN 60529 and IEC 529
6. Material : Aluminium
7. Paint : Epoxy Signal Red RAL3001 suitable for a marine environment
8. Climatic protection : Suitable from -20C to +40C
9. Weight : 18 kg
10. Crossing earth terminal : M6

Tech-Ex Systems Limited Tel : 02476 792 620 Mob : 0787 508 3496 Email : harnak.sandhu@tech-exsystems.com

..	HS	Date	03/03/2022	Customer	..		Exd Enclosure - G23 Material : Aluminium Enclosure	Project Name		..
01	HS	Check	HS	Order Number	..			Drawing Number		..
00	As Built	02/03/2022	HS	Signed	hs				
Rev.	Comment	Date	Name									

1 2 3 4 5 6 7 8